

REVISIONS				
REV.	DESCRIPTION	ECN	DATE	APPD
A	RELEASED FOR PRODUCTION	930	7/15/2019	JAM

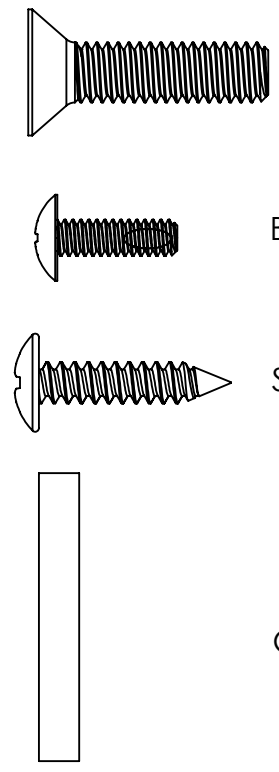
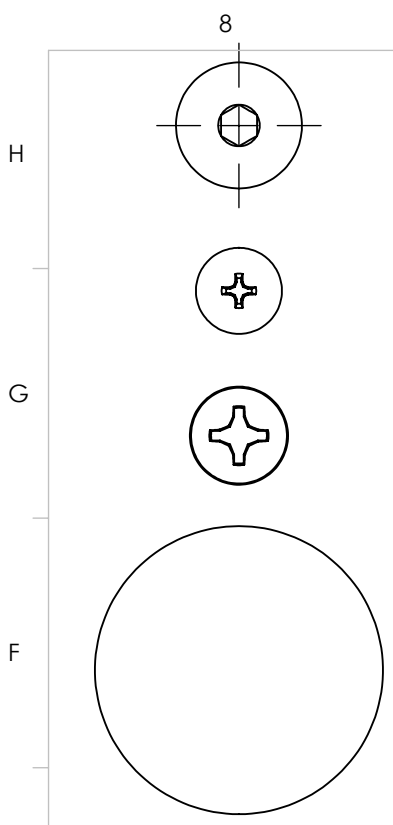

Bolt, 5/16-18 x 1-1/4, FH, Hex, Black, w/ Patch, Bin (x4)

Bolt, 10-24 x 5/8, TH, PHIL, Zinc, w/ Patch (x16)

Screw, #12 x 1, TH, PHIL, Black (X16)

Glide, Felt, 1-1/2" Dia. x XX" Thick, Stick-On, Tan (x8)

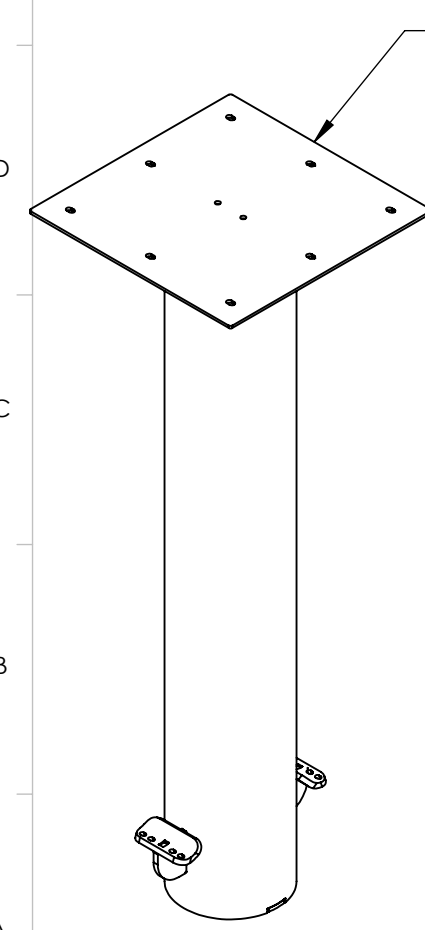
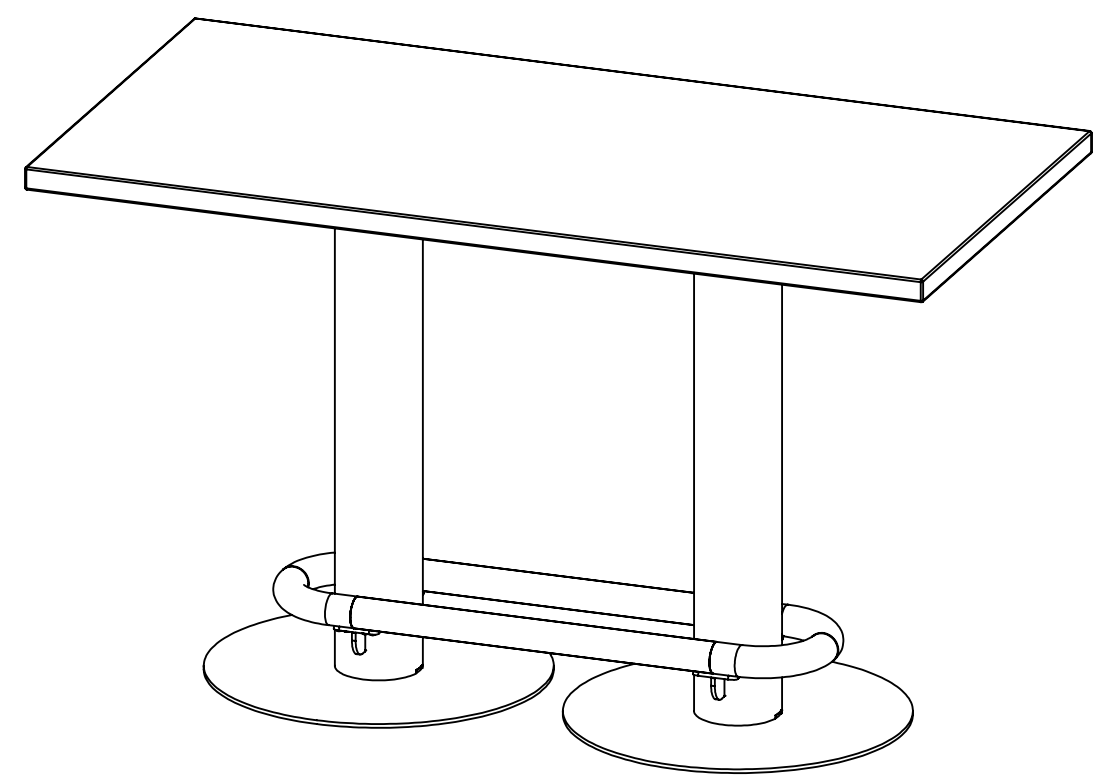

Column, Frankie, FNK, Welded (x2)

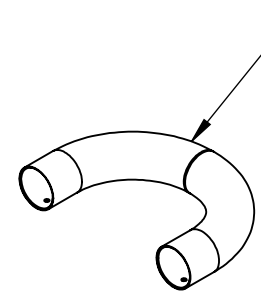

Footrest U Tube, Frankie, FNK, Raw (x2)

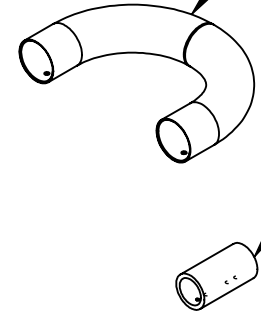

Sleeve Insert, Frankie, FNK, CMN, Inner Splice, Raw (x4)

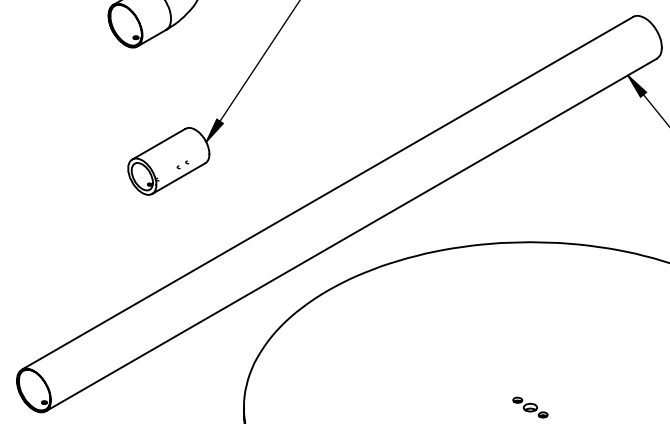

Footrest Tube, Frankie, FNK, Raw(x2)

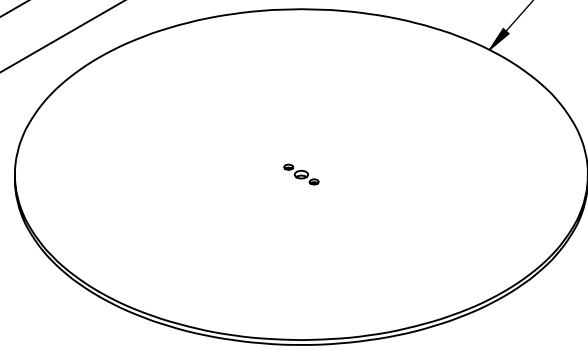

Plate, Rambo, Base (x2)

UNLESS OTHERWISE SPECIFIED:
 DIMENSIONS ARE IN INCHES
 TOLERANCES:
 FRACTIONAL ± .030
 ANGULAR: MACH ± 1° BEND ± 1°
 TWO PLACE DECIMAL ± .030
 THREE PLACE DECIMAL ± .015

PROPRIETARY AND CONFIDENTIAL
 THE INFORMATION CONTAINED IN THIS DRAWING IS THE SOLE PROPERTY OF GRAND RAPIDS CHAIR CO. ANY REPRODUCTION IN PART OR AS A WHOLE WITHOUT THE WRITTEN PERMISSION OF GRAND RAPIDS CHAIR CO. IS PROHIBITED.

GRAND RAPIDS CHAIR CO
 1250 84th Street, Grand Rapids MI, USA

Drawn By: jmoshauer
 Drawing Date: 7/15/2019

Finish:
 Material Specification:

Part Number:
040007

Description:
 Assembly Instructions for Frankie Bar Height/ Counter Height

Type:	SW Tab:	Sheet:
	COMPONENTS	Sheet 1 of 1

LAST SAVED: jmoshauer Friday, December 6, 2019 9:11:44 AM; FILENAME: N:\Engineering\1. Product Data\Frankie Table\30 CAD Data\ECN 930 Counter and Pub Height\Instructions for Frankie Bar Height-Counter Height, Rev A, 20190715

REVISIONS				
REV.	DESCRIPTION	ECN	DATE	APPD
A	RELEASED FOR PRODUCTION	930	7/15/2019	JAM

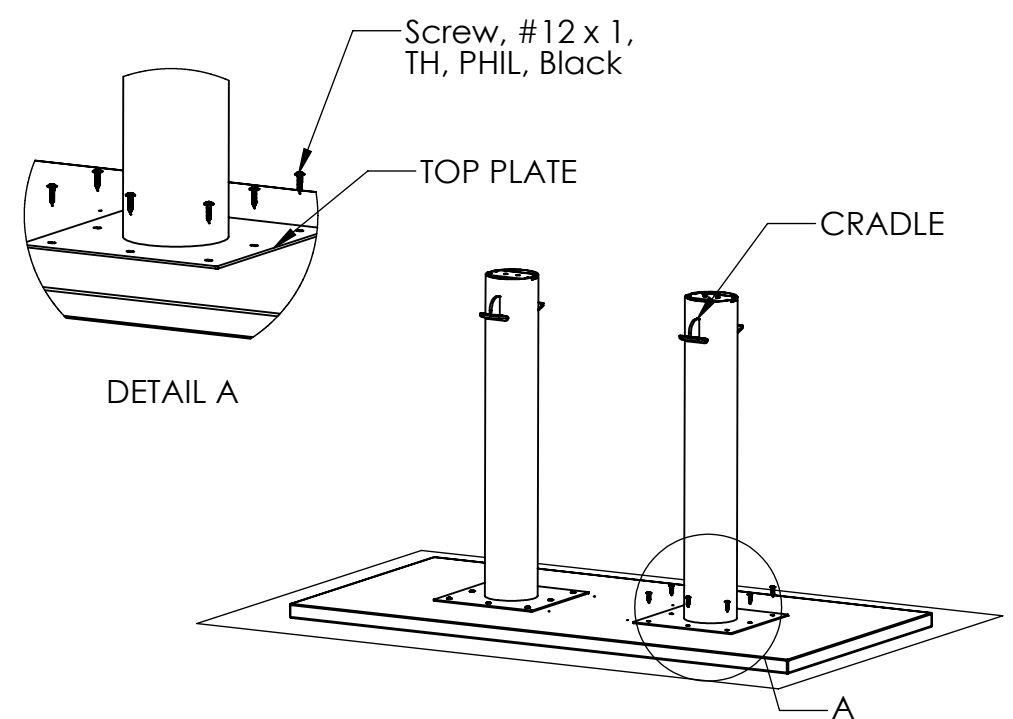

PLACE TABLE TOP UPSIDE DOWN ON A SCRATCH FREE SURFACE. PLACE (2) COLUMNS ON TABLE TOP AND MATCH UP HOLES ON TABLE TOP TO TOP PLATE. LOOSELY FASTEN (8) SCREWS TO TABLE TOP THRU TOP PLATE. ALIGN CRADLE PARALLEL TO WIDTH OF TABLE.

STEP 1

S-1

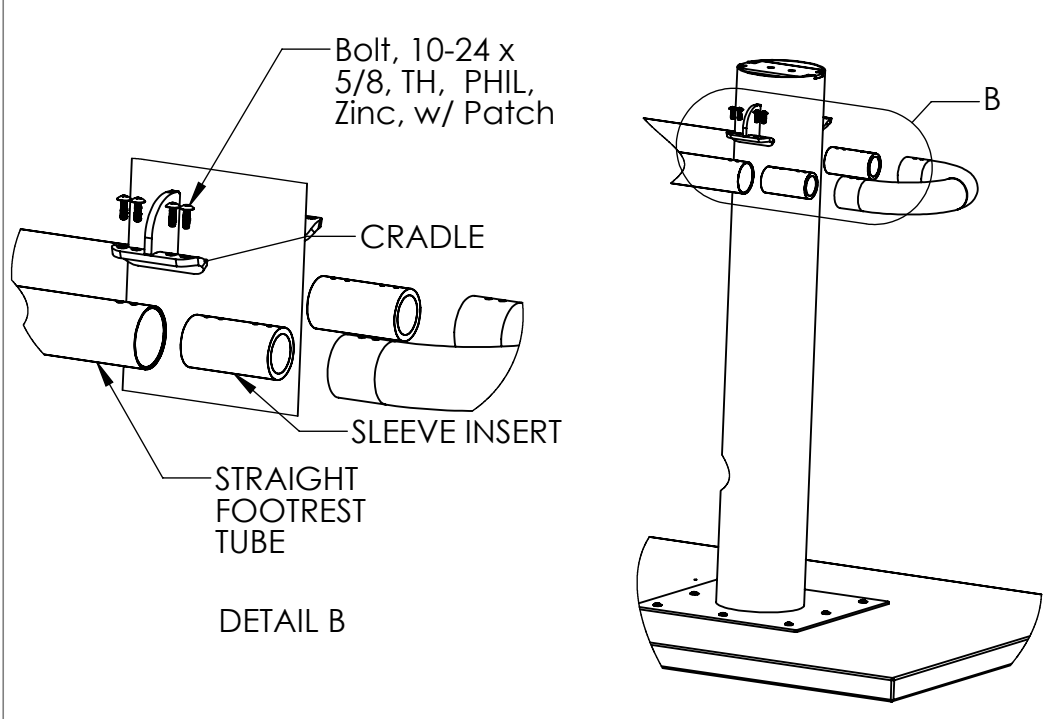

LINE THE HOLES IN THE STRAIGHT TUBE UP TO THE SLOTS IN THE CRADLE. PLACE INNER PIPE INSIDE AND SECURE USING (2) 10-24 x 1/2 BOLTS. DO THIS (4) TIMES, (2) PER COLUMN. DO NOT COMPLETELY TIGHTEN AT THIS POINT.

STEP 2

S-2

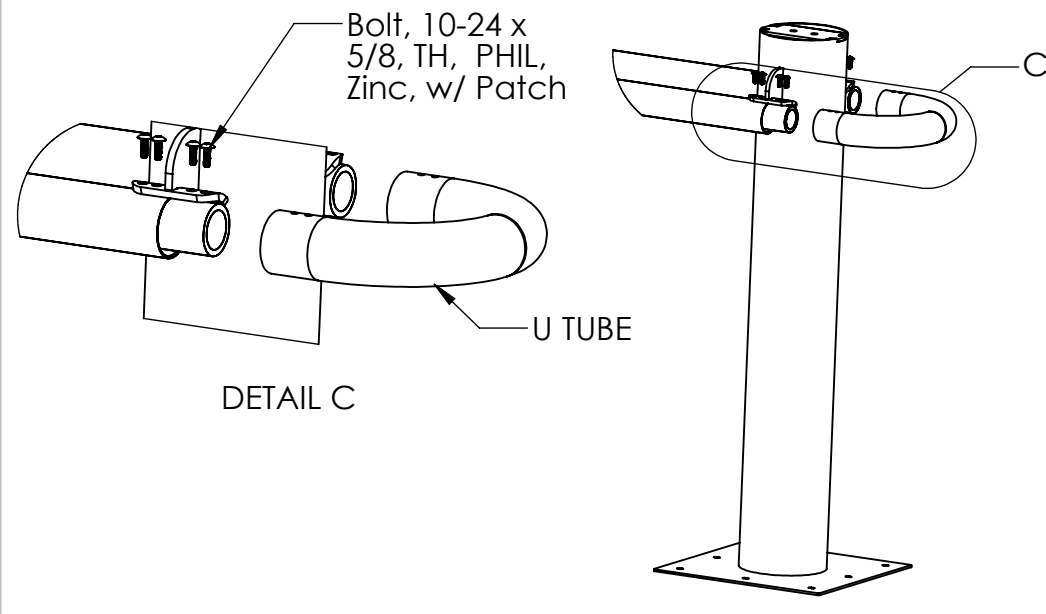

ONCE SECURED, LINE UP HOLES IN U TUBE TO SLOTS IN CRADLE. ATTACH U-TUBE TO END USING (4) 10-24 x 1/2 BOLTS (903013). DO THIS (2) TIMES. COMPLETELY TIGHTEN ALL BOLTS SECURING THE FOOTREST AT THIS TIME.

STEP 3

S-3

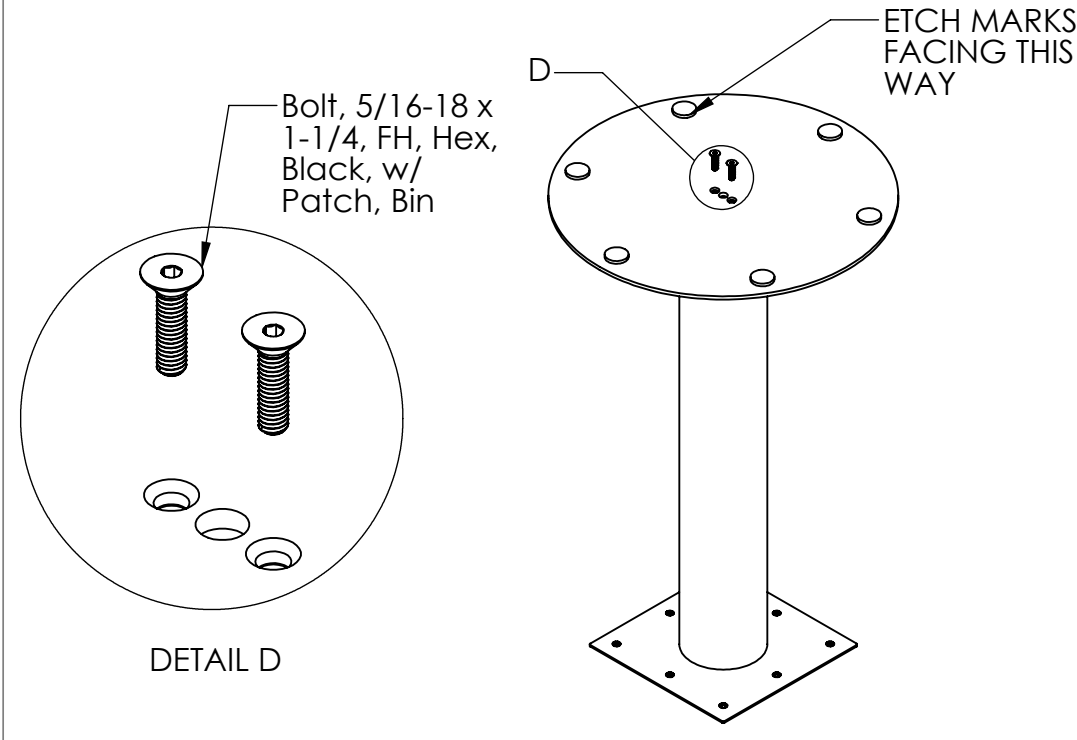

WHILE TABLE IS STILL UPSIDE DOWN, SECURE BASE PLATE TO COLUMN. MATCH (2) HOLES UP AND SECURE BASE PLATE USING (2) 5/16-18 x 1-1/4 BOLTS. DO THIS (2) TIMES.

STEP 4

S-4

UNLESS OTHERWISE SPECIFIED:
 DIMENSIONS ARE IN INCHES
 TOLERANCES:
 FRACTIONAL ± .030
 ANGULAR: MACH ± 1° BEND ± 1°
 TWO PLACE DECIMAL ± .030
 THREE PLACE DECIMAL ± .015

PROPRIETARY AND CONFIDENTIAL
 THE INFORMATION CONTAINED IN THIS DRAWING IS THE SOLE PROPERTY OF GRAND RAPIDS CHAIR CO. ANY REPRODUCTION IN PART OR AS A WHOLE WITHOUT THE WRITTEN PERMISSION OF GRAND RAPIDS CHAIR CO. IS PROHIBITED.

GRAND RAPIDS CHAIR CO
 1250 84th Street, Grand Rapids MI, USA

Drawn By: jmoshauer
 Drawing Date: 7/15/2019

Finish:

Material Specification:
 See Individual Prints

Part Number:
040007

Description:
 Assembly Instructions for Frankie Bar Height/ Counter Height

Type: Manufactured	SW Tab: INSTRUCTIONS PG 1	Sheet: Sheet 1 of 1
-----------------------	------------------------------	------------------------

LAST SAVED: jmoshauer Friday, December 6, 2019 9:11:44 AM; FILENAME: N:\Engineering\1. Product Data\Frankie Tables\30 CAD Data\ECN 930 Counter and Pub Height\Instructions for Frankie Bar Height-Counter Height, Rev A, 20190715

REVISIONS				
REV.	DESCRIPTION	ECN	DATE	APPD
A	RELEASED FOR PRODUCTION	930	7/15/2019	JAM

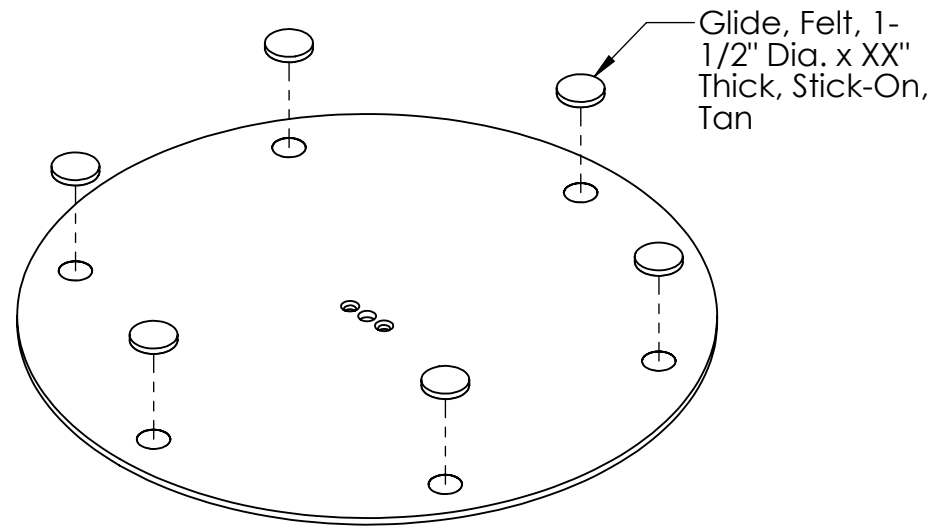

PLACE (4) GLIDES (184457) ON THE UNDERSIDE. LOCATE ETCH MARKS AND PLACE GLIDE OVERTOP THE ETCH.

STEP 5

S-5

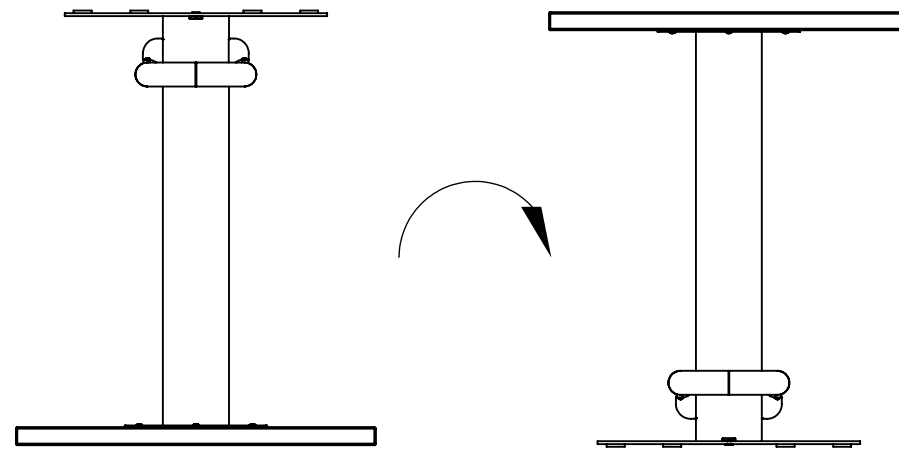

USING (2) PEOPLE MINIMUM, ROTATE TABLE UPRIGHT.

STEP 6

S-6

GRAND RAPIDS CHAIR CO
1250 84th Street, Grand Rapids MI, USA

Drawn By: jmoshauer

Drawing Date: 7/15/2019

Finish:

Material Specification:

See Individual Prints

Part Number:

040007

Description:

Assembly Instructions for Frankie Bar Height/ Counter Height

UNLESS OTHERWISE SPECIFIED:
DIMENSIONS ARE IN INCHES
TOLERANCES:
FRACTIONAL ± .030
ANGULAR: MACH ± 1° BEND ± 1°
TWO PLACE DECIMAL ± .030
THREE PLACE DECIMAL ± .015

PROPRIETARY AND CONFIDENTIAL
THE INFORMATION CONTAINED IN THIS DRAWING IS THE SOLE PROPERTY OF GRAND RAPIDS CHAIR CO. ANY REPRODUCTION IN PART OR AS A WHOLE WITHOUT THE WRITTEN PERMISSION OF GRAND RAPIDS CHAIR CO. IS PROHIBITED.

Type: Manufactured

SW Tab: INSTRUCTIONS, PG 2

Sheet: Sheet 1 of 1

LAST SAVED: jmoshauer Friday, December 6, 2019 9:11:44 AM; FILENAME: N:\Engineering\1. Product Data\Franke Table\30 CAD Data\ECN 930 Counter and Pub Height\Instructions for Frankie Bar Height-Counter Height, Rev A, 20190715